

Multi-Pass Automotive Synthetic Aperture Radar Image Fusion

2023 IEEE Radar Conference // 05.04.2023

Jason M. Merlo* and **Jeffrey A. Nanzer**
Michigan State University, East Lansing, MI, USA



delta
Distributed Electromagnetics
Theory and Applications

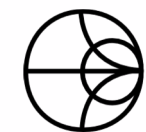

emrg
Electromagnetics Research Group
Michigan State University



Outline

1. Motivation & Background
2. Image Fusion
3. Data Collection
4. Experimental Results

Applications

Multi-Pass Automotive Synthetic Aperture Radar



Fast
↑
Revisiting Interval
↓
Slow

Rapid revisiting interval (Cooperative)

- Increased spatial diversity and angular resolution
- Increased system gain
- Improved probability of detection
- Relative localization

Long revisiting interval

- Vehicle localization and odometry
- Road change/hazard detection

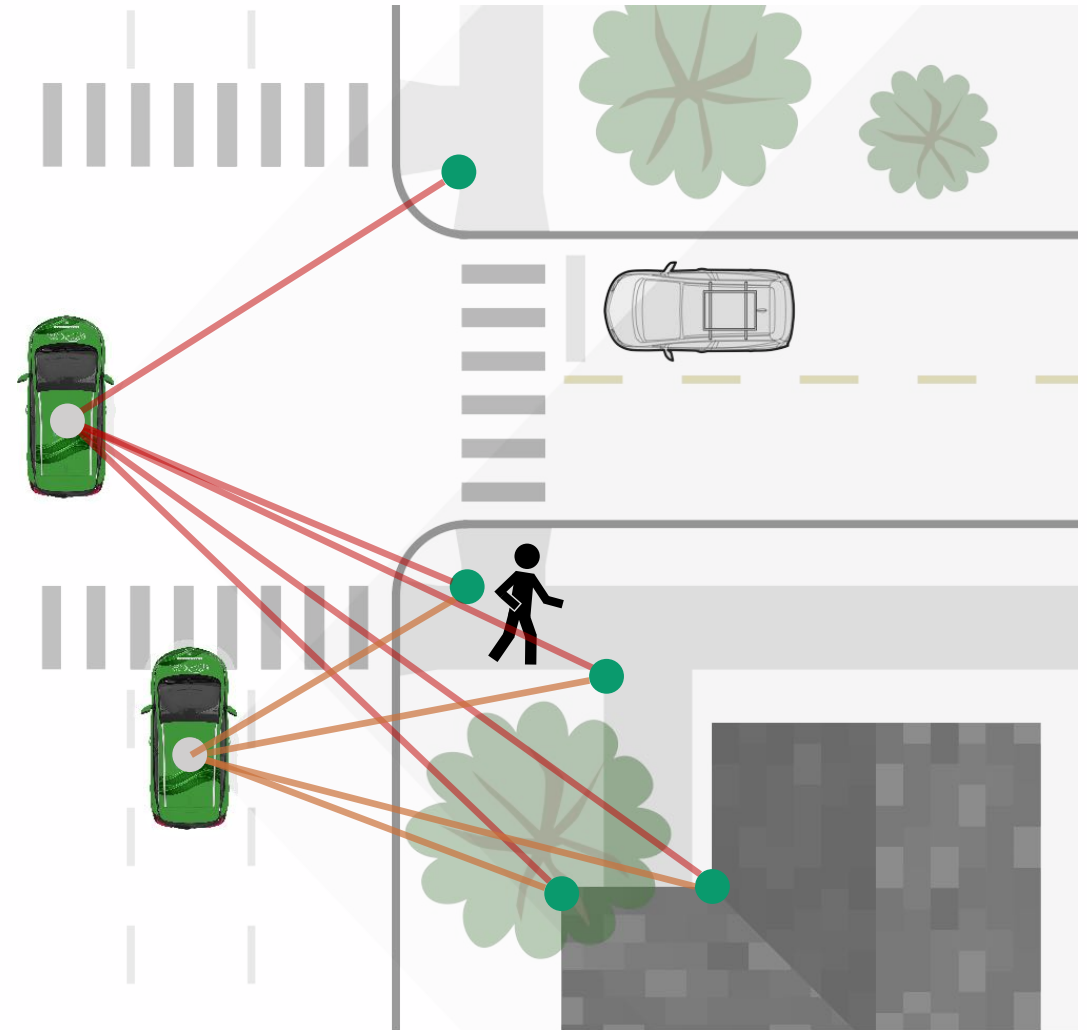

● Radar Map Landmarks

Motivation of This Work



- Automated vehicles require accurate localization and environmental awareness
- Vehicles are becoming more connected (V2X)
- Can we reuse existing communications frequencies for sensing on AVs?

C-Band Automotive SAR Images

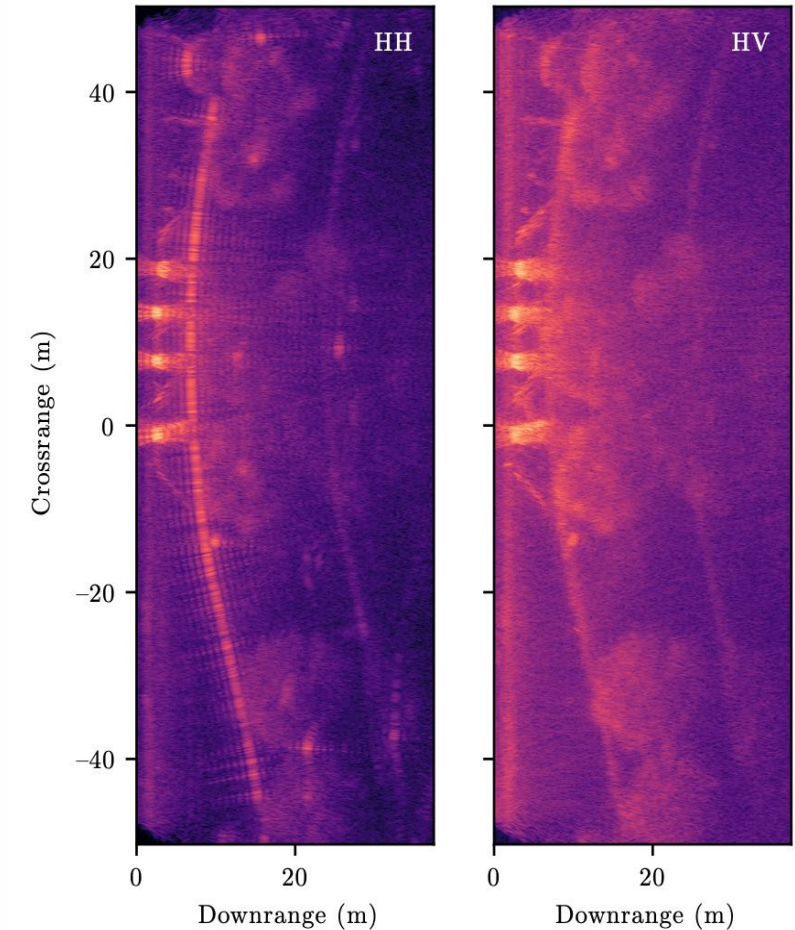

J. M. Merlo and J. A. Nanzer, "A C-Band Fully Polarimetric Automotive Synthetic Aperture Radar," in *IEEE Transactions on Vehicular Technology*, vol. 71, no. 3, pp. 2587-2600, March 2022, doi: 10.1109/TVT.2021.3138348.



Image Formation Algorithm

Range Migration Algorithm (RMA / Omega- k)

- ✓ Efficient image formation using Fast Fourier Transforms (FFTs)
- ✓ Focuses well across all ranges (large depth of field)
- ✓ Focuses well across with wide imaging swaths (wide field of view)
- ✗ Requires uniform sampling along cross-range axis

Possible solutions:

- a. Use an inverse method to form image from nonuniform samples (*if* accurate sample locations are available)
- b. Correct for scene distortion using a reference image
 - + Provides sub-aperture motion vector corrections for odometry and localization
 - + Provides stacked global/relative referenced SAR images for further processing

Synthetic Aperture Image Fusion



Multi-pass SAR Image

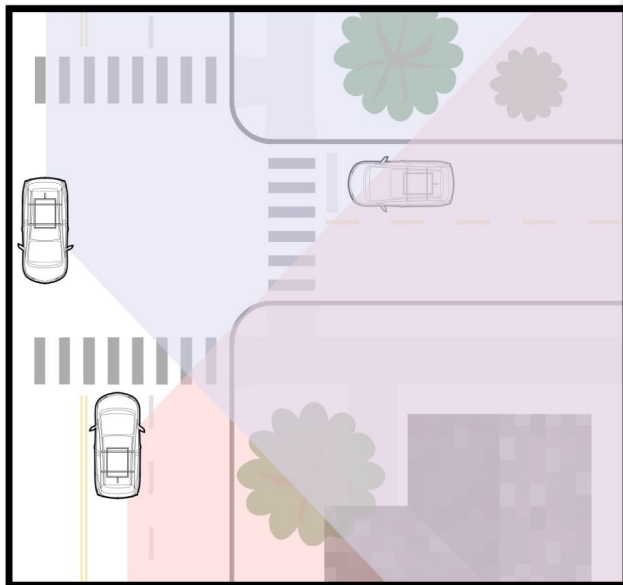

Align and Stack

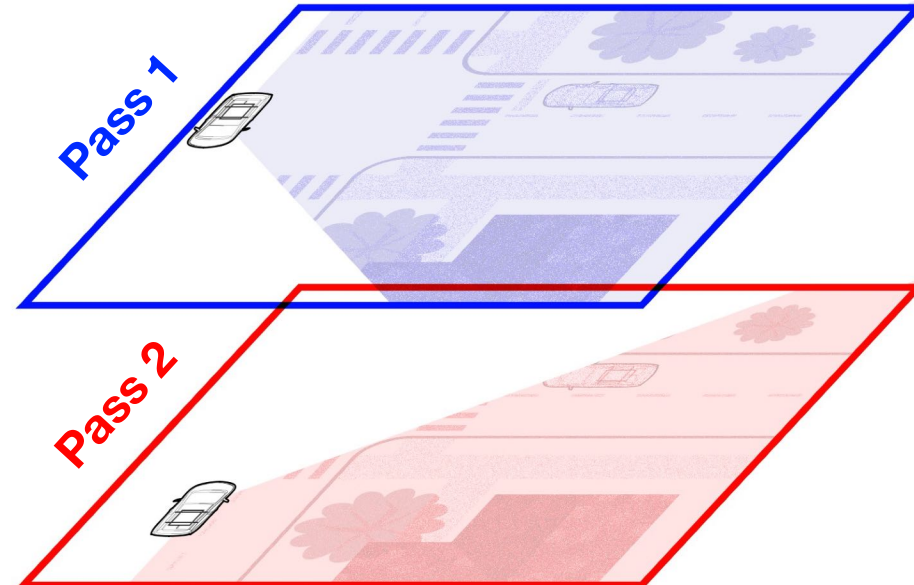

Incoherent Summation

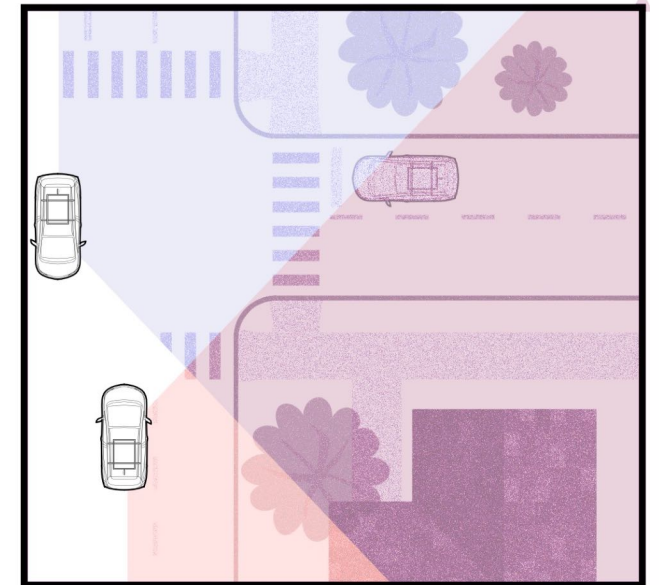

Synthetic Aperture Image Fusion



Multi-pass SAR Image

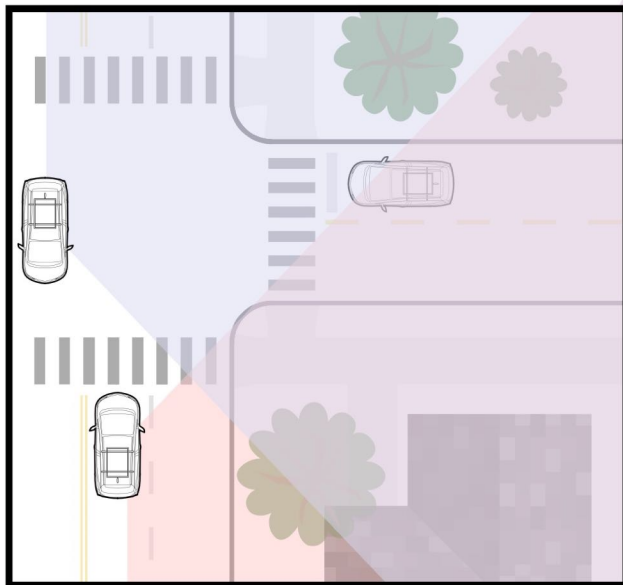

Align and Stack

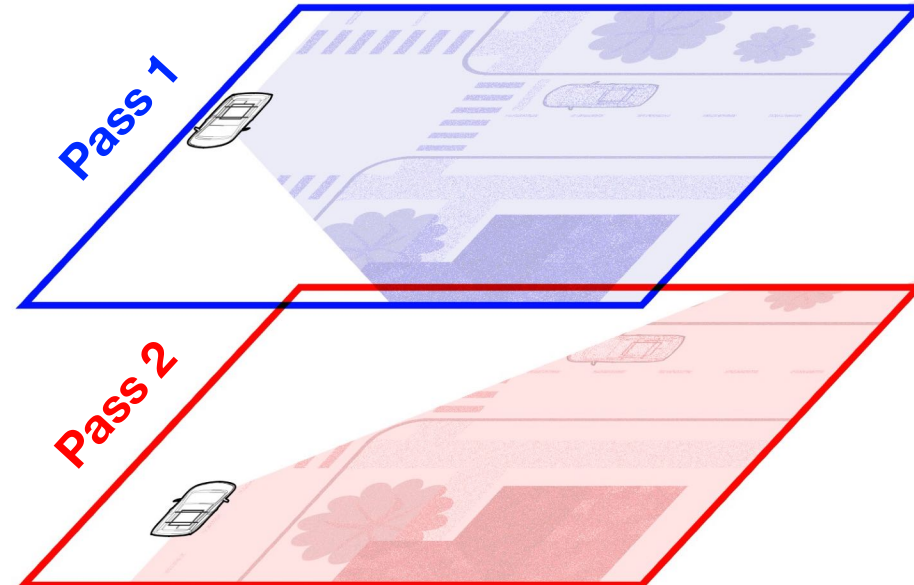

Incoherent Summation

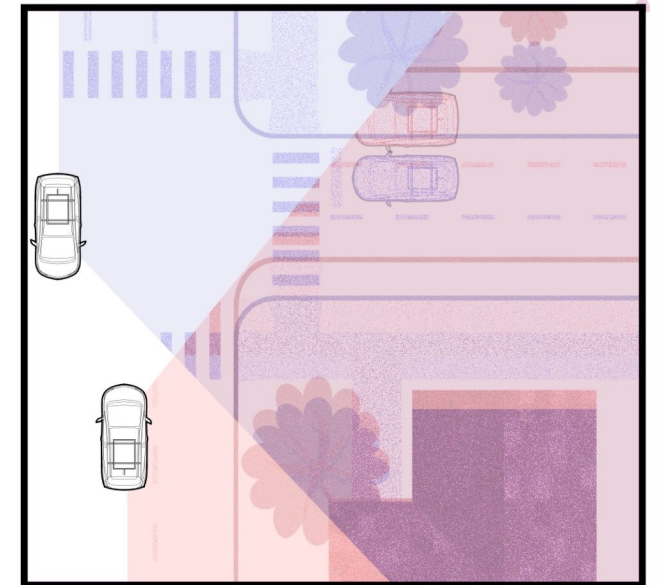



Image Fusion

2D Correlation-Based Image Alignment

- Translates scene along x and y axes to point of maximum correlation

$$\begin{aligned} r_{fg}(x_0, y_0) &= \sum_{x=0}^{M-1} \sum_{y=0}^{N-1} f(x, y)g^*(x - x_0, y - y_0) \\ &= \mathcal{F}^{-1}\{F(x, y)G^*(x, y)\} \end{aligned}$$

where

- M, N are the image width and height, respectively
- F and G are the Fourier transform pairs of f and g

[1] M. Guizar-Sicairos, S. T. Thurman, and J. R. Fienup, "Efficient subpixel image registration algorithms," *Opt. Lett.*, vol. 33, no. 2, pp. 156–158, Jan 2008. [Online]. Available: <https://opg.optica.org/ol/abstract.cfm?URI=ol-33-2-156>



Image Fusion

2D Correlation-Based Image Alignment

- Translates scene along x and y axes to point of maximum correlation

$$\overrightarrow{r_{\text{align}}}(f, g) = \underset{x_0, y_0}{\operatorname{argmax}} |r_{fg}(x_0, y_0)|$$

[1] M. Guizar-Sicairos, S. T. Thurman, and J. R. Fienup, "Efficient subpixel image registration algorithms," *Opt. Lett.*, vol. 33, no. 2, pp. 156–158, Jan 2008. [Online]. Available: <https://opg.optica.org/ol/abstract.cfm?URI=ol-33-2-156>



Image Fusion

Full Scene Alignment

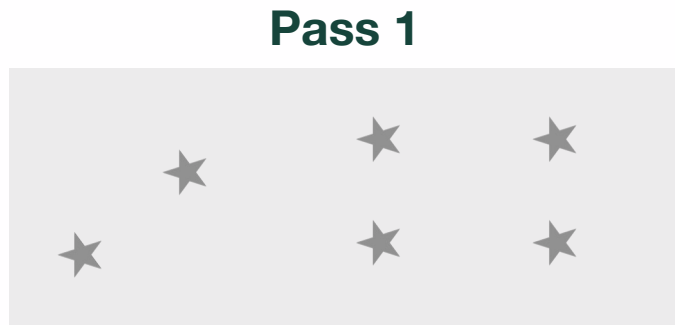

Due to constant velocity assumption
features become misaligned



Image Fusion

Chunk Alignment

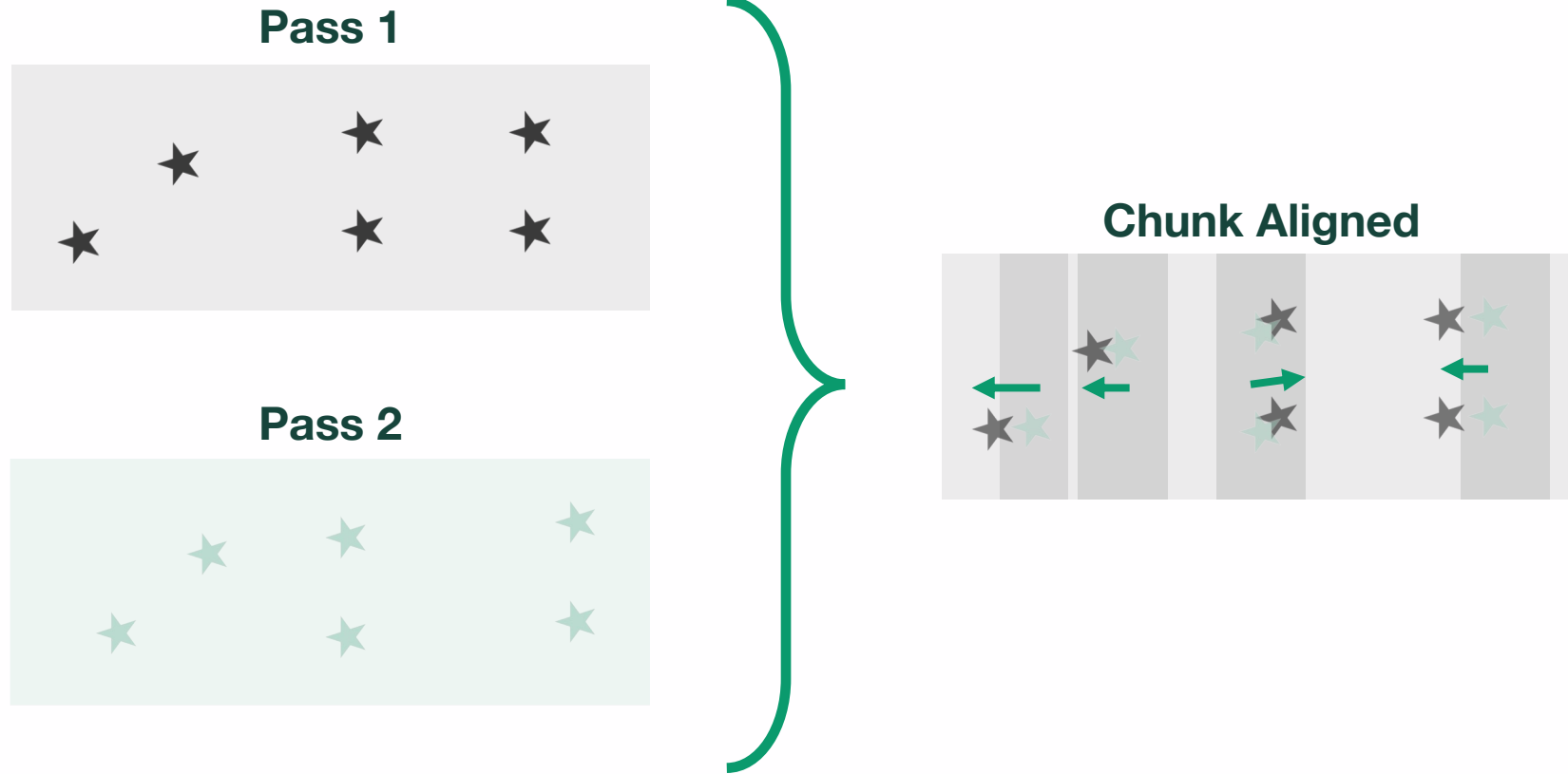
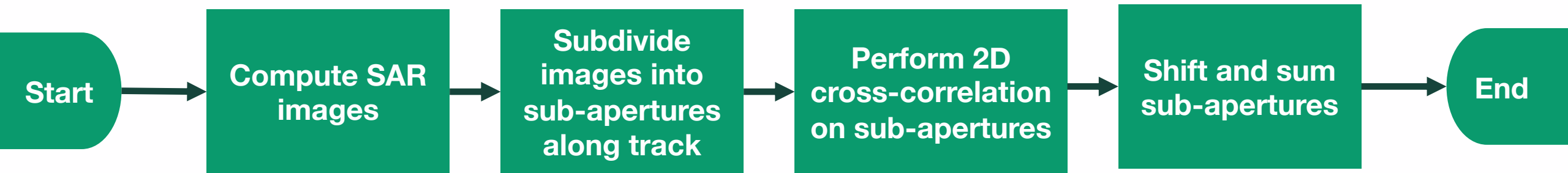

Image Fusion

Chunk Alignment Process





Data Collection System

System Architecture

- Frequency-modulated continuous-wave
- Direct downconversion
- Fully Polarimetric

Waveform Parameters

- $f_c = 5.9$ GHz
- BW = 200 MHz
- $\tau_p = 1.0$ ms
- PRF = ~75 Hz

Data Acquisition

- $f_s = 100$ kSps/ch
- Software Triggered

Hardware Schematic

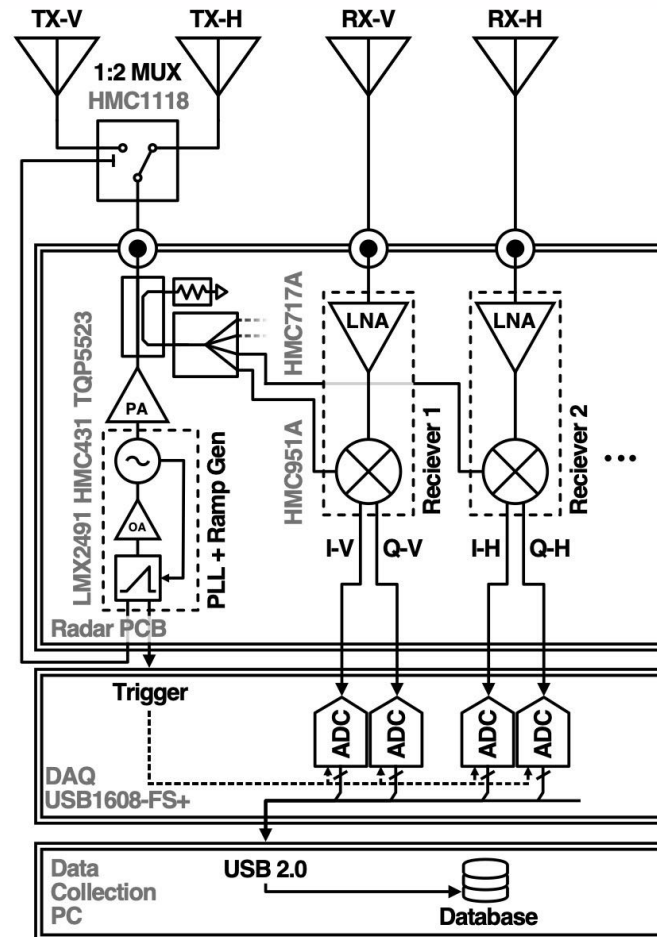

Assembled System

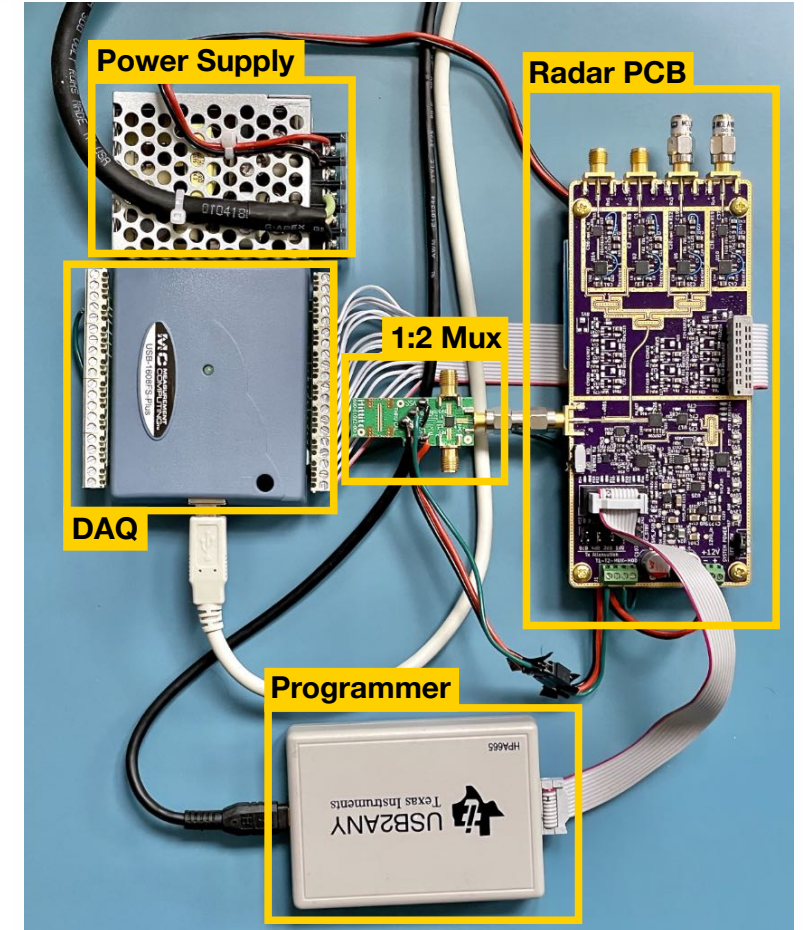

Data Collection Platform



MSU CANVAS Chevrolet Bolt AV

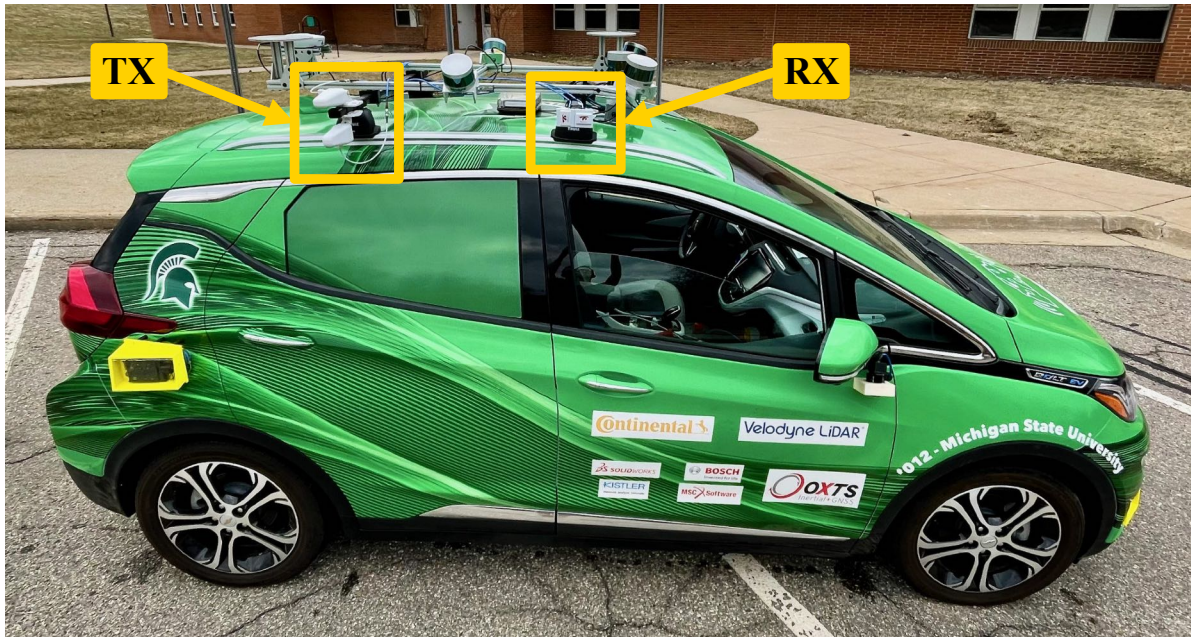

Platform Data Flow Architecture

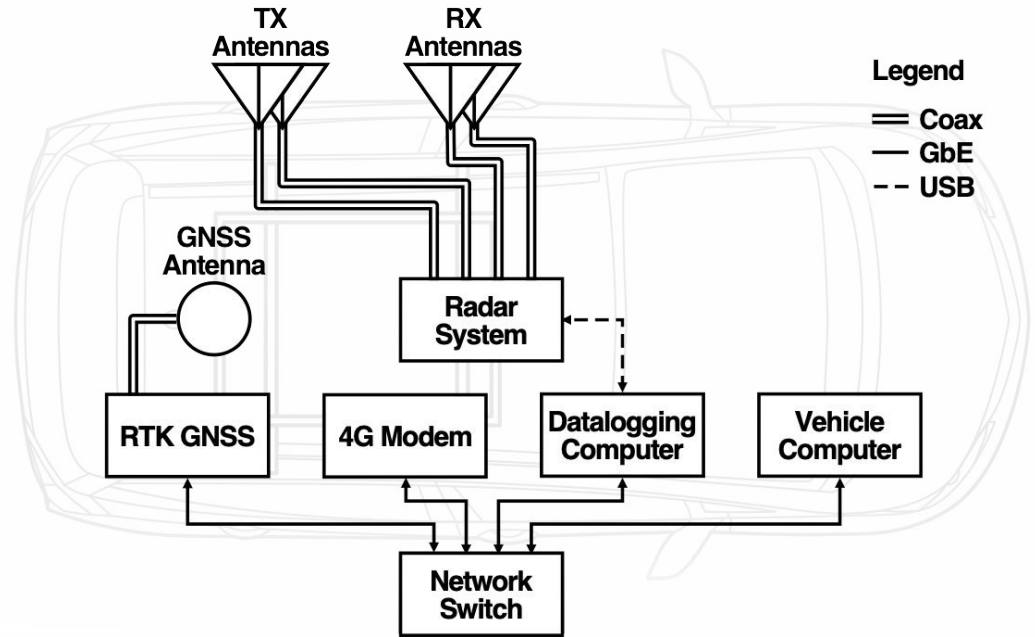

Antenna Parameters

- Transmit Antenna Gain: 13.2 dBi
- Receive Antenna Gain: 9.5 dBi

- Transmit Antenna HPBW: 40°
- Receive Antenna HPBW: 65°

Scene 1 | Two Passes

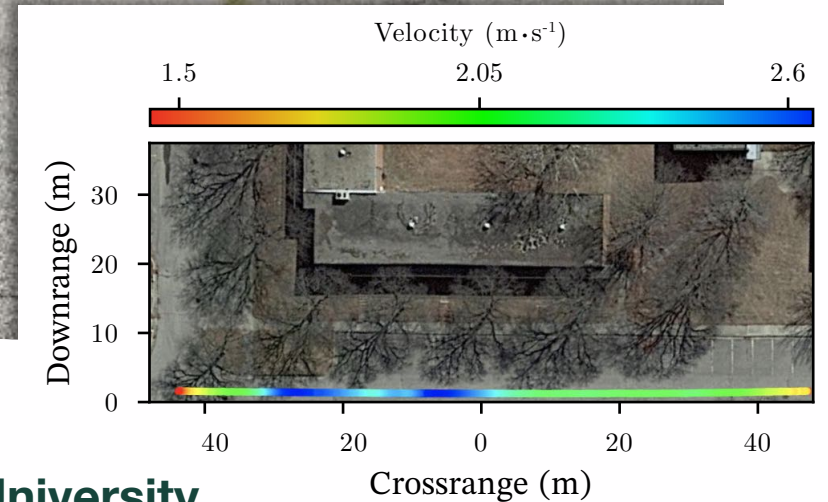

Spartan Village Autonomous Vehicle Test Facility, Michigan State University

Scene 1 | Two Passes

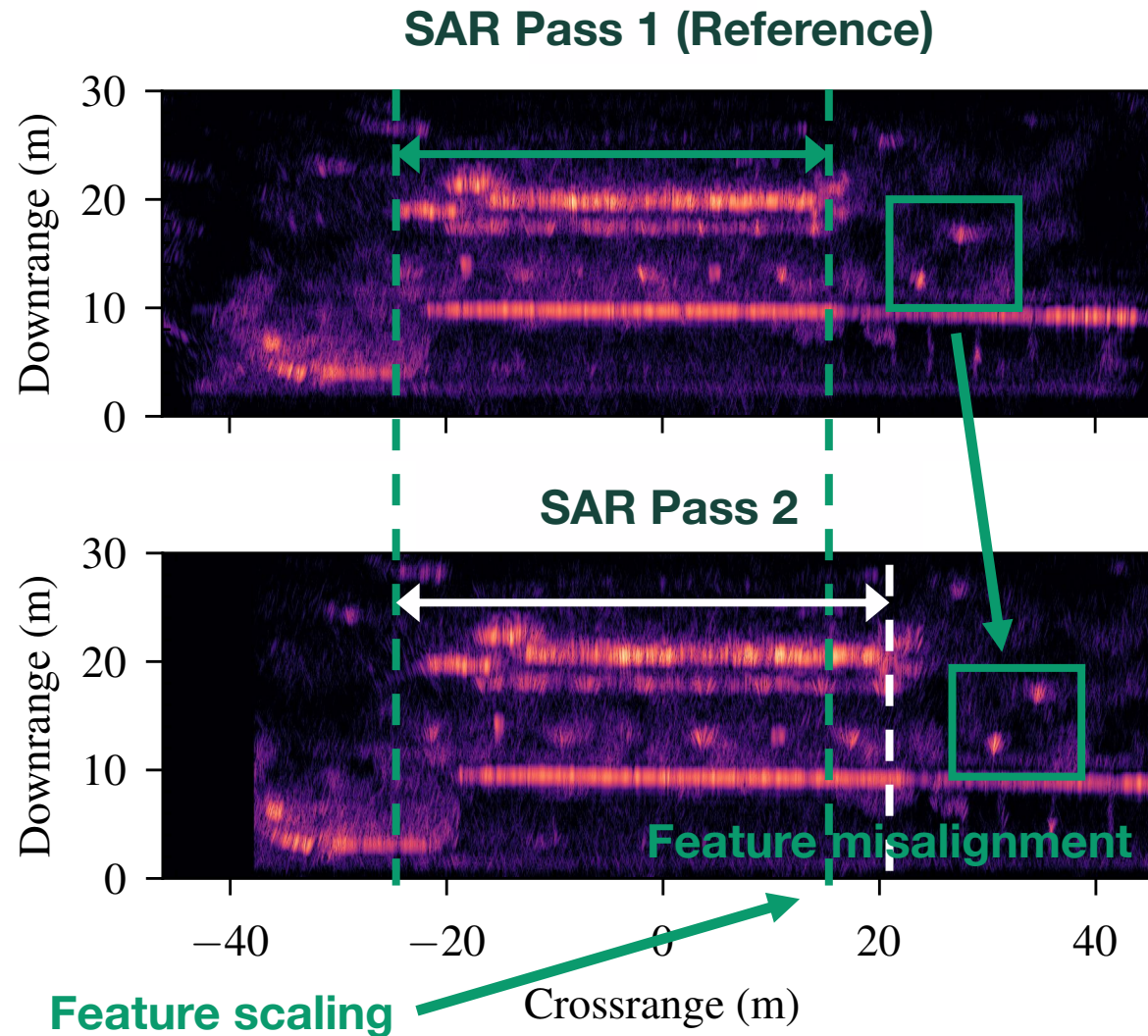

Scene 1 | Two Passes



SAR Pass 1 (Reference)

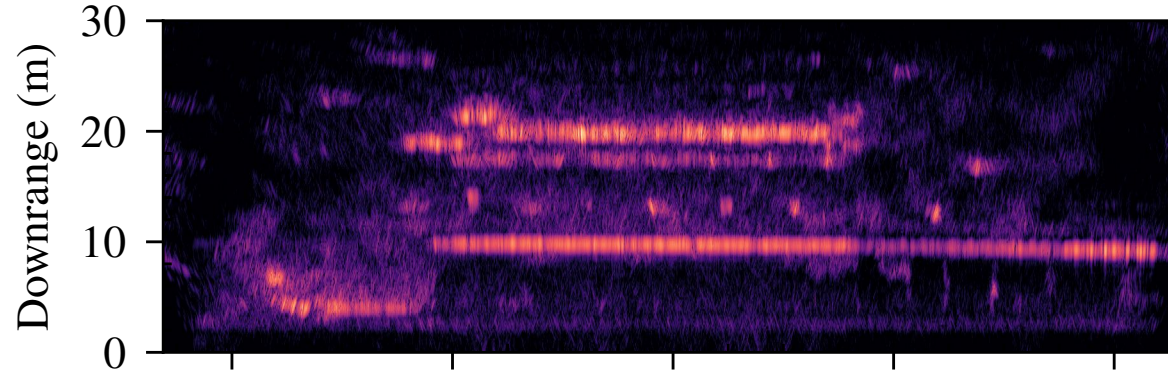

Along-Track Blurring

Full Scene Aligned

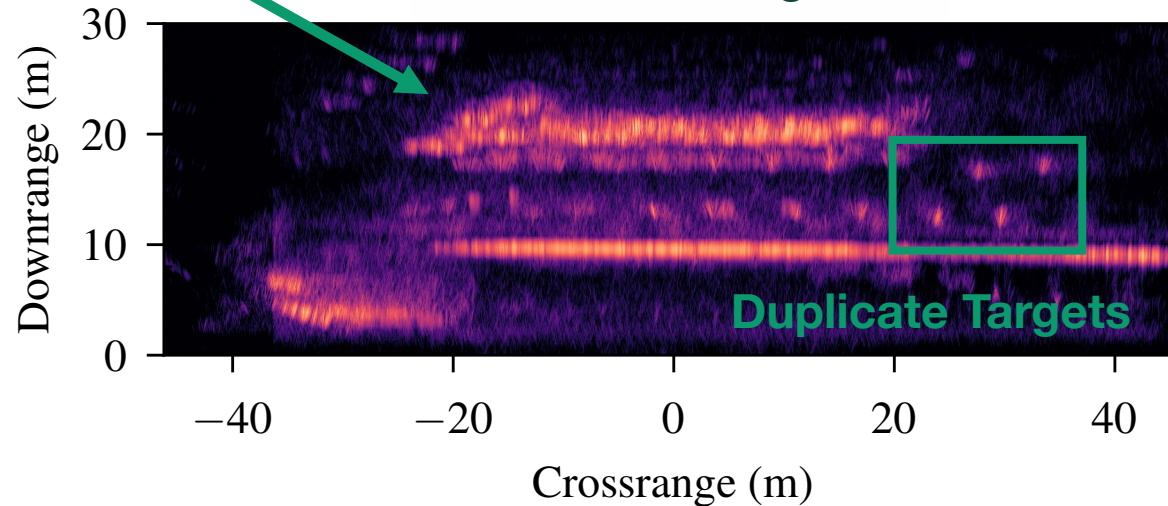

Scene 1 | Two Passes



SAR Pass 1 (Reference)

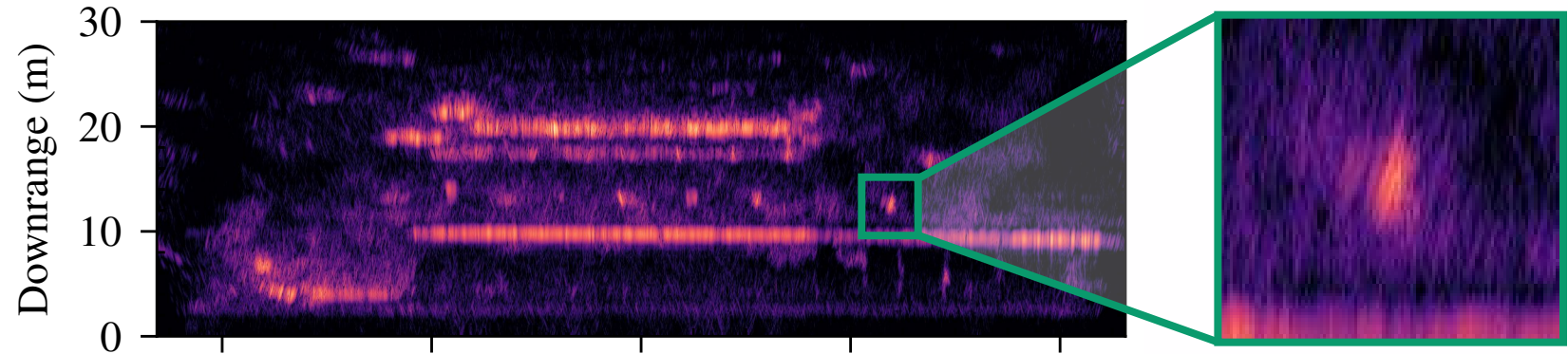

Chunk Aligned

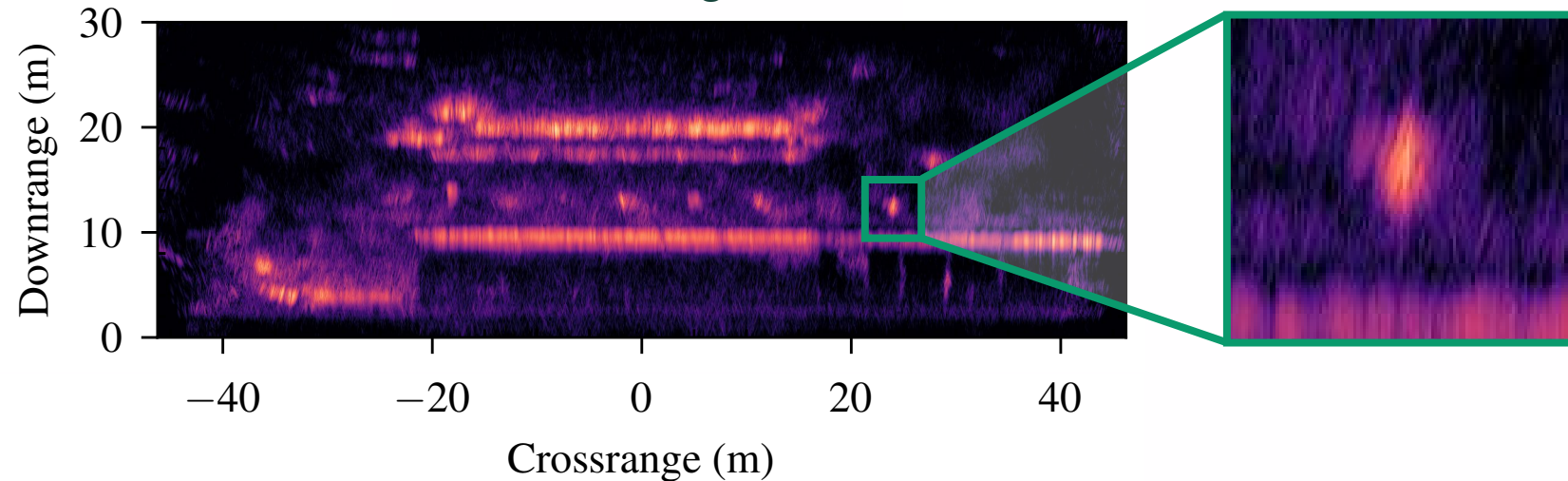

Scene 2 | Three Passes

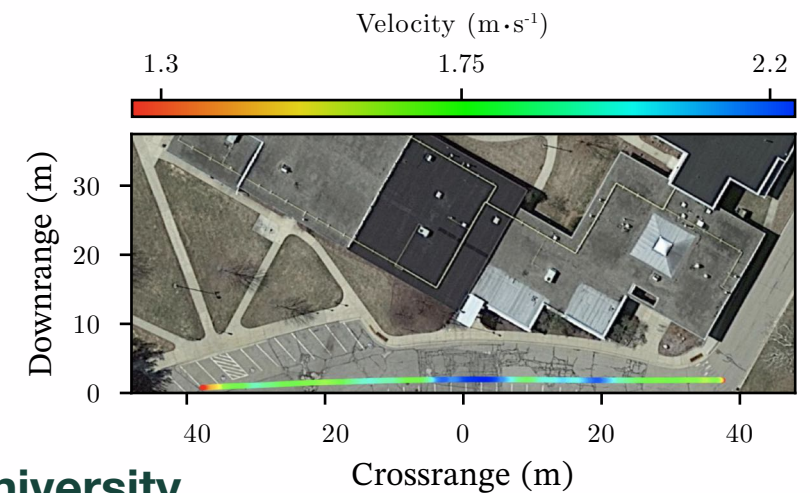

Spartan Village Autonomous Vehicle Test Facility, Michigan State University

Scene 2 | Three Passes



SAR Pass 1 (Reference)

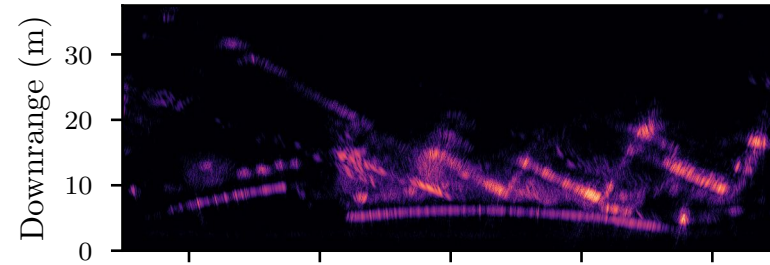

SAR Pass 2

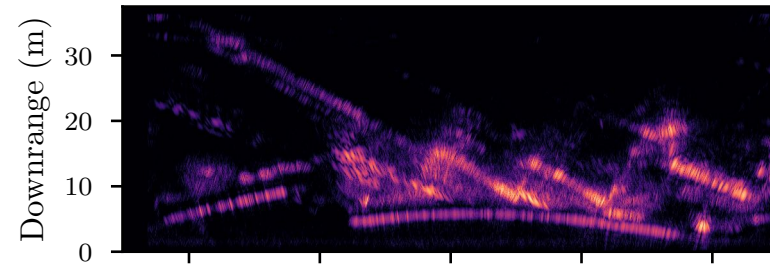

SAR Pass 3

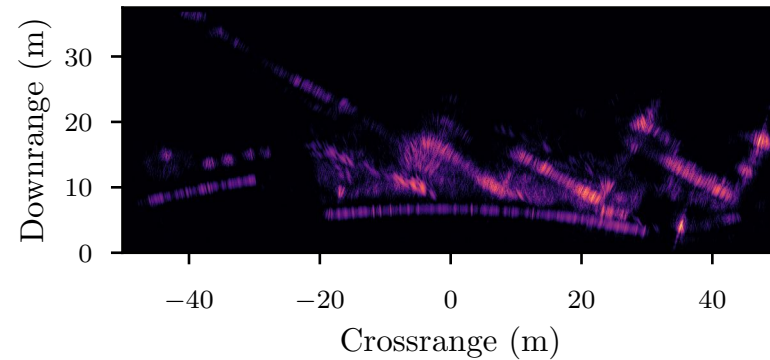

Scene 2 | Three Passes



Full Scene Aligned

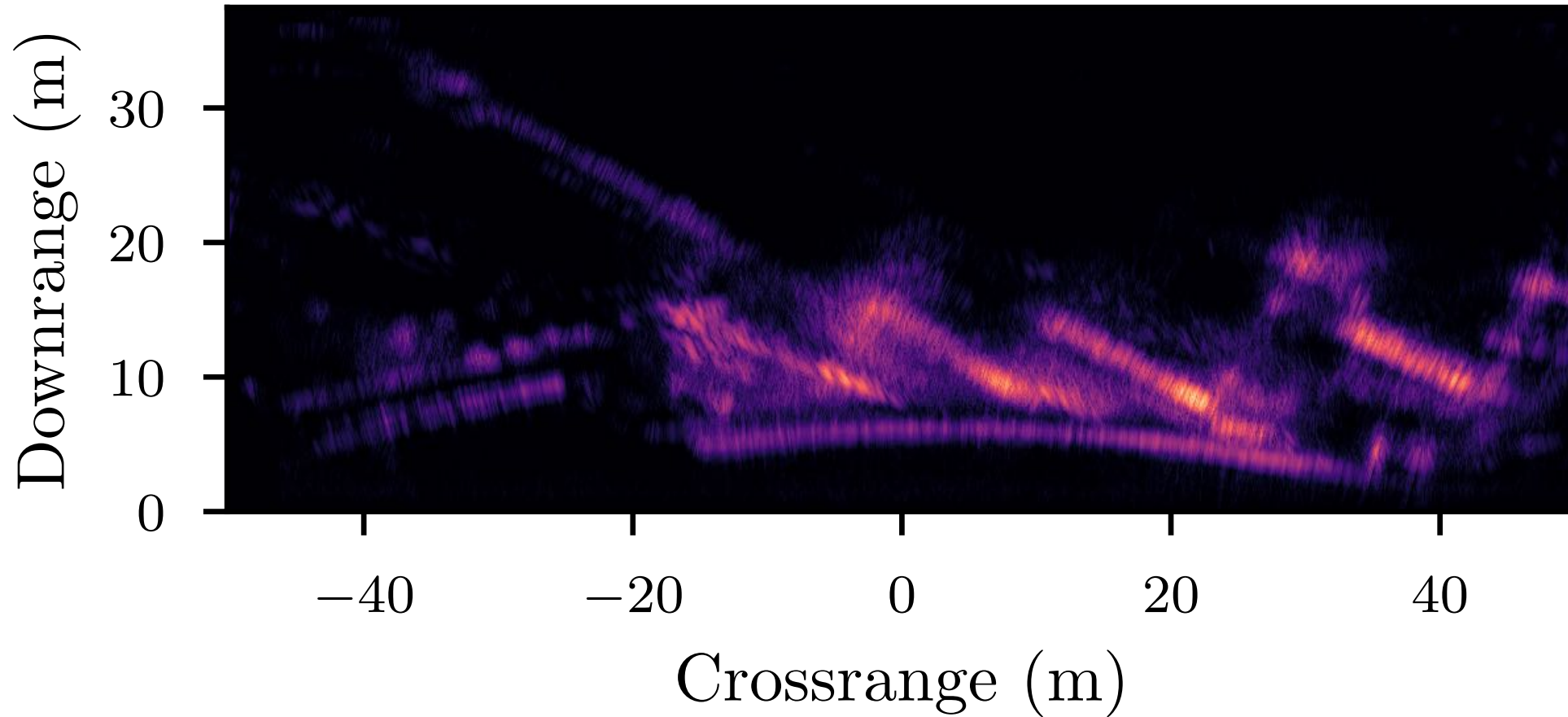

Scene 2 | Three Passes



Chunk Aligned

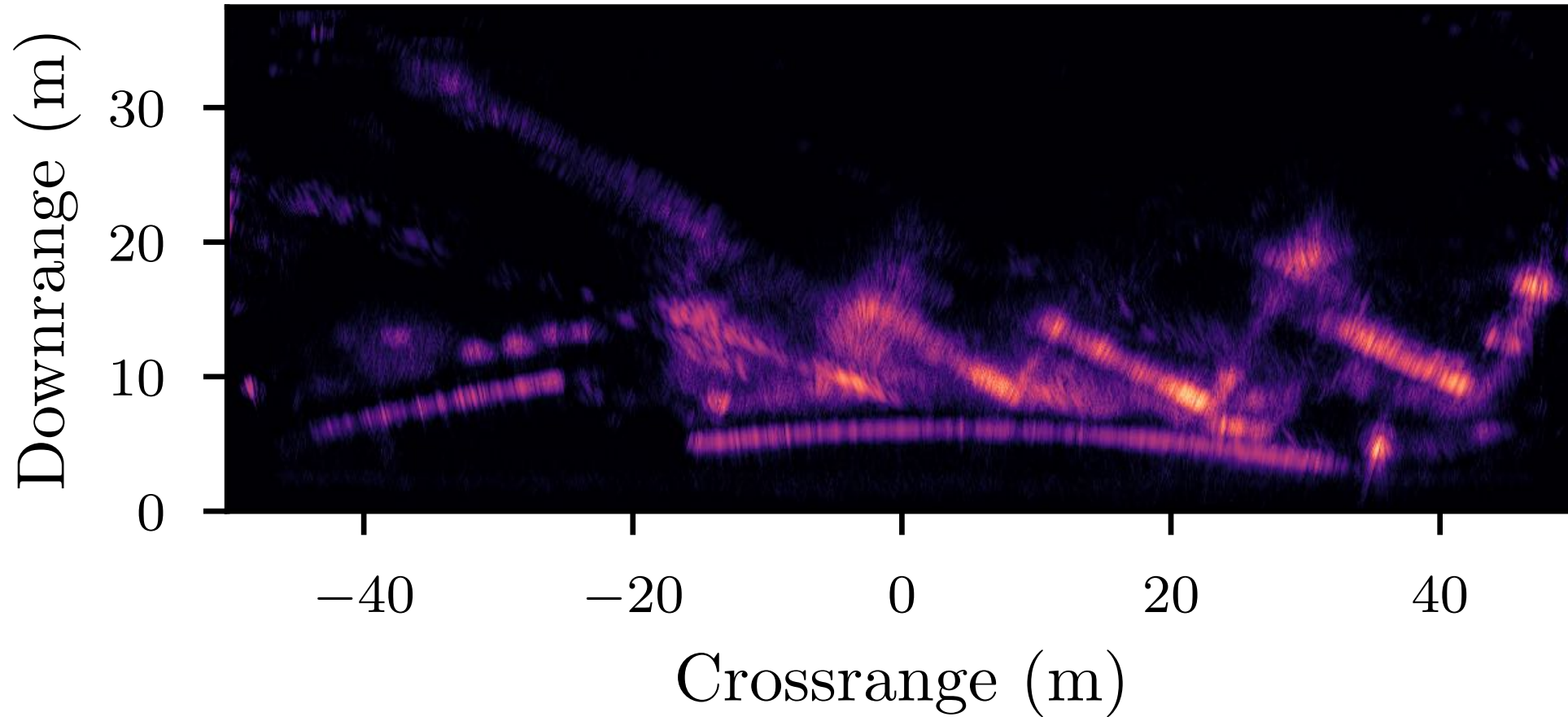

Scene 3 | Three Passes



Spartan Village Autonomous Vehicle Test Facility, Michigan State University

05.04.2023

Scene 3 | Three Passes



SAR Pass 1 (Reference)

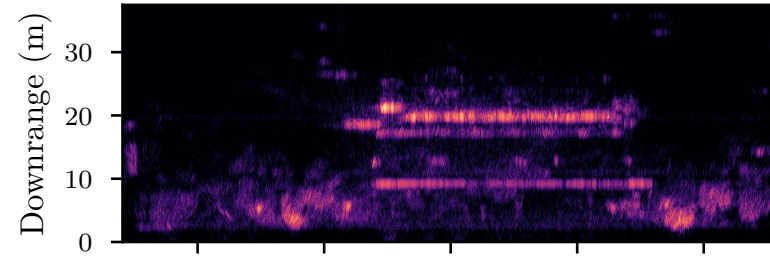

SAR Pass 2

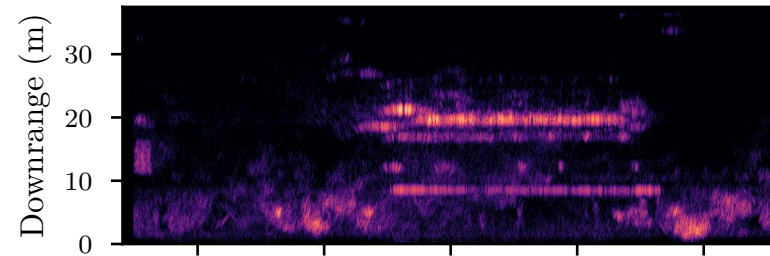

SAR Pass 3

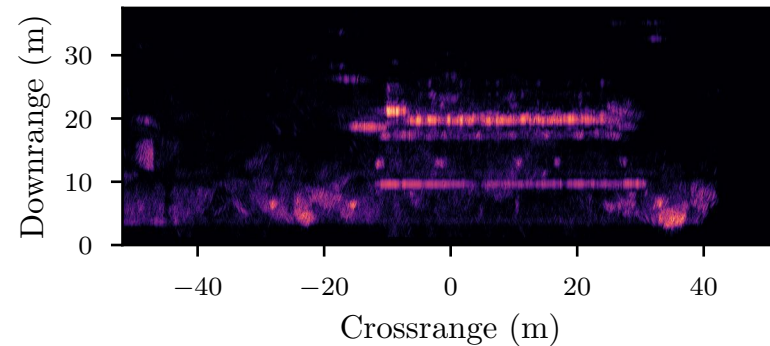

Scene 3 | Three Passes



Full Scene Aligned

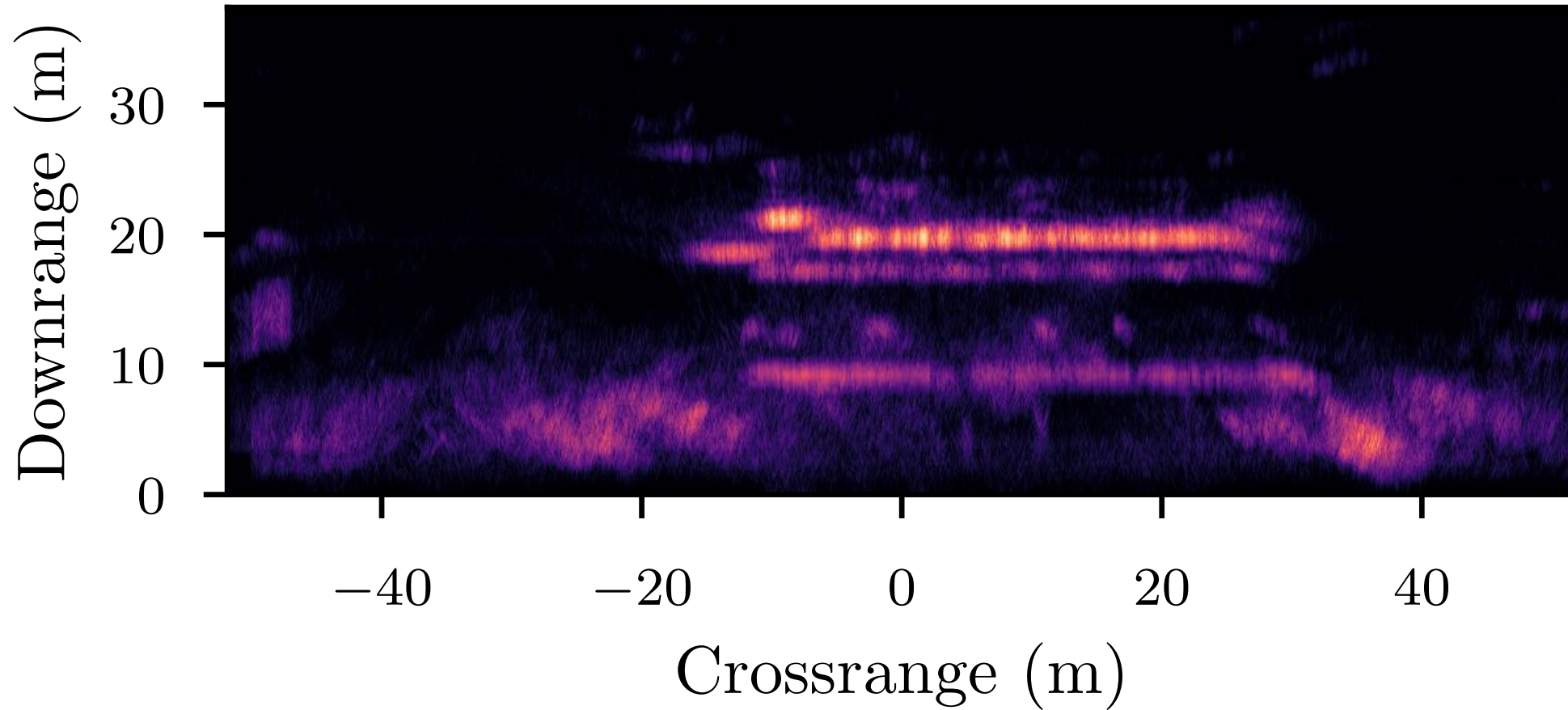

Scene 3 | Three Passes



Chunk Aligned

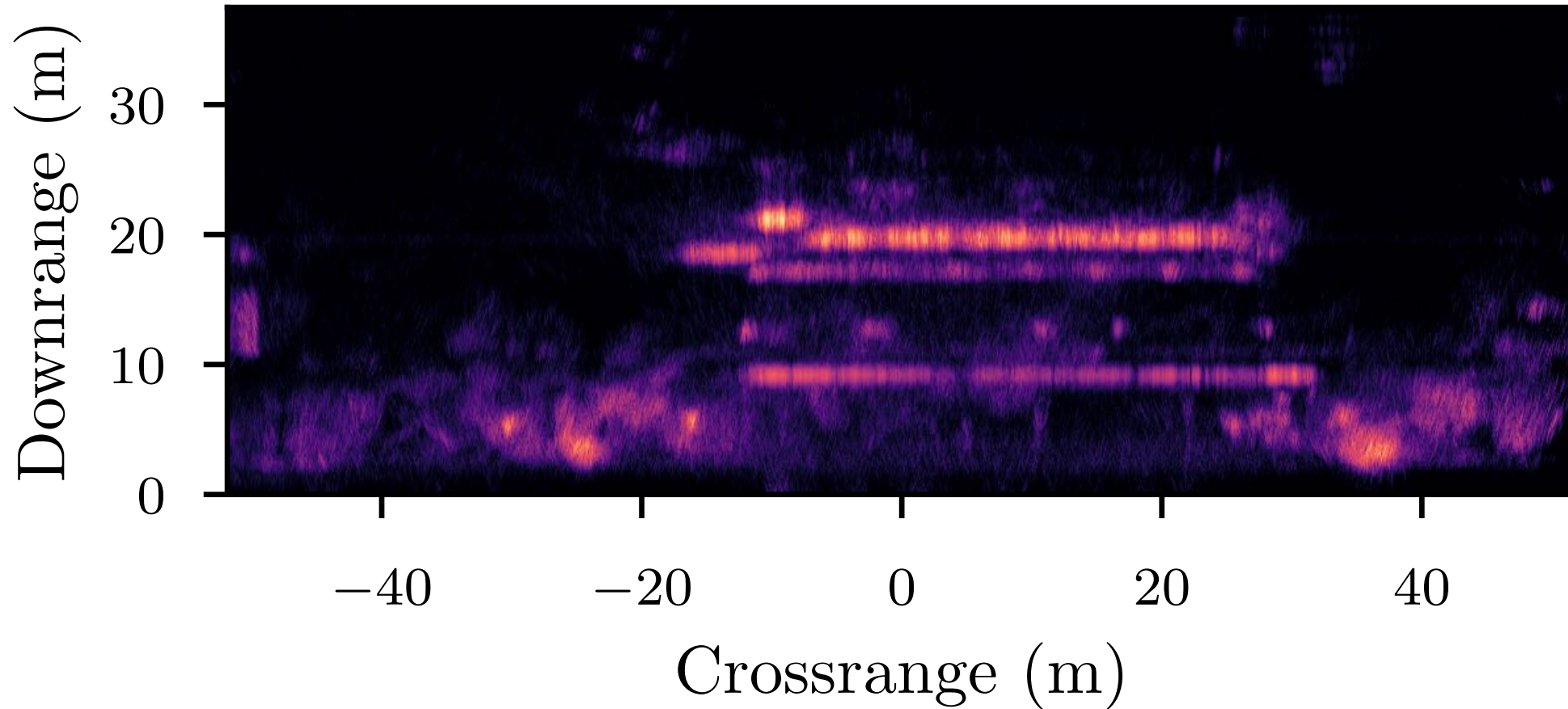

Conclusion



- Proposed a simple technique for **C-band automotive SAR image fusion**
- Utilizes **efficient range migration algorithm** for image formation
- **Compensates for motion distortion** using sub-aperture alignment method
- **Experimentally demonstrated scene fusion** on three scenes in the C-band



Thank You

Contact: merlojas@msu.edu



A | Backup Slides

Platform Motion Model



Assumptions:

- Constant motion
- Stop-and-go approximation

Position Model:

$$x_n = n v_a \tau_p$$

where

n : pulse number

v_a : platform velocity

τ_p : pulse repetition interval

Platform Motion

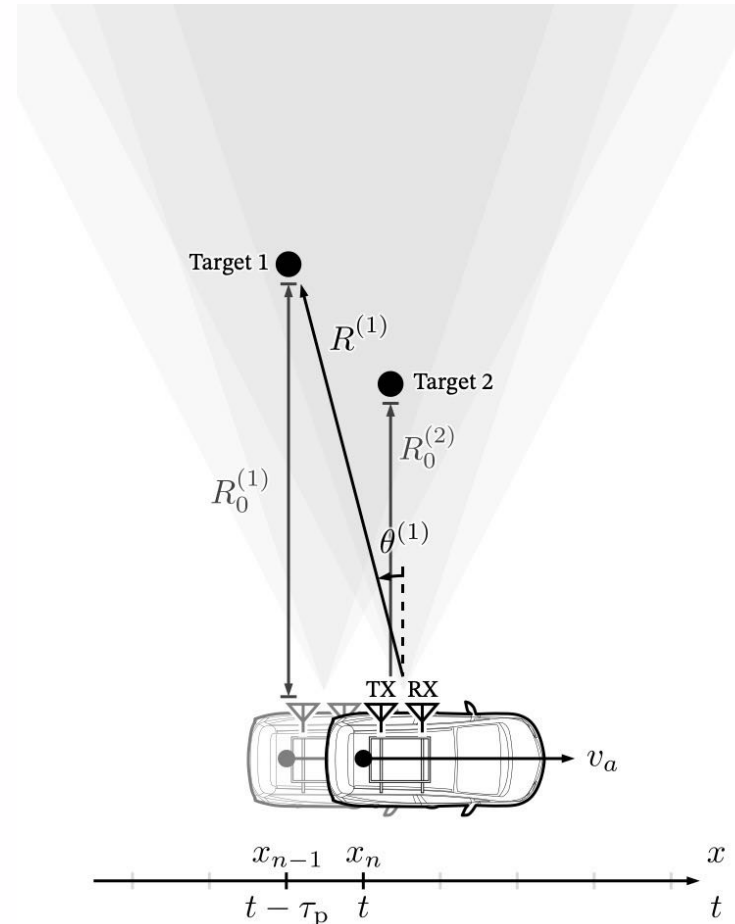

Target Range vs. Position

